

# ELEVATOR INSTALLATION PRODUCT RANGE

## Leading the Way

Power Climber is the **global leader** in scaffoldless elevator installation access solutions.

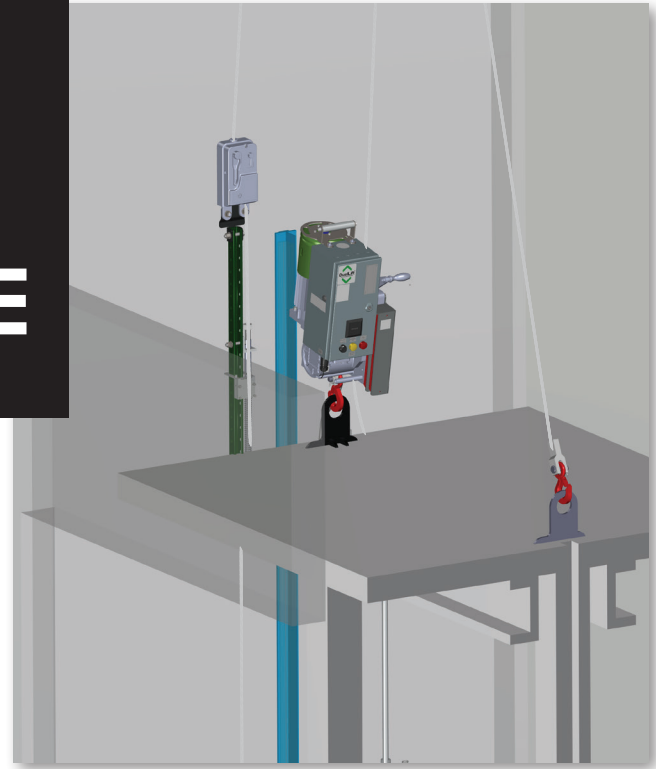

The equipment and accessories you need for **ANY** elevator installation project.

**Power Climber** designs and manufactures the broadest range of personnel and material hoists available on the market, including models specifically designed for scaffoldless elevator installation.

Combined with our full line of components, accessories, and rigging solutions, Power Climber has everything you need to perform scaffoldless elevator installation at any jobsite.

## Power Climber and DualLift

Power Climber joined forces with DualLift in 2015.

Together, we design and manufacture hoists, platforms, rigging equipment and accessories used around the globe for personnel and material lifting. Our products appear in a wide range of applications and industries, including commercial construction and renovation, elevator installation, energy and industrial facility maintenance, and infrastructure projects.



**PowerClimber®**



**DualLift®**

## Why Power Climber?

- Proven history of working globally with all major elevator OEMs.
- Largest manufacturer of personnel and material hoists in the world.
- Variable Frequency Drive (VFD) technology.
- Global sales and service, including 24/7 support and multiple local service partners.
- Custom solutions available through fully integrated engineering, manufacturing, and support teams.
- All hoists designed in Germany, Belgium and the United States. Manufactured in Germany and Belgium.
- Manufacturing facilities certified compliant with ISO 14001, 45001 and 9001 standards.
- Continuous product innovation and improvement based on customer feedback.

## Elevator Installation Applications

### UpLite Cargo Material Hoist

- > 100, 300, 500 kg capacity
- > Bi-directional lifting (coming soon)

### Wire Rope

- > Available in 6.5 mm (for material hoists), 8.4 mm, 9 mm, 10.2 mm and 14 mm (all for man-riding)
- > All ropes are qualified for our hoists and safety devices according to EN 1808

### Traction Hoist

- > Titan (650 kg) (shown with built-in overspeed safety device)
- > UpPro 10 (1000 kg)
- > UpPro P2514 (2500 kg)

### False Car (for reference only)

### Rope Counterweight

- > Provides tension to prevent slack in secondary wire rope

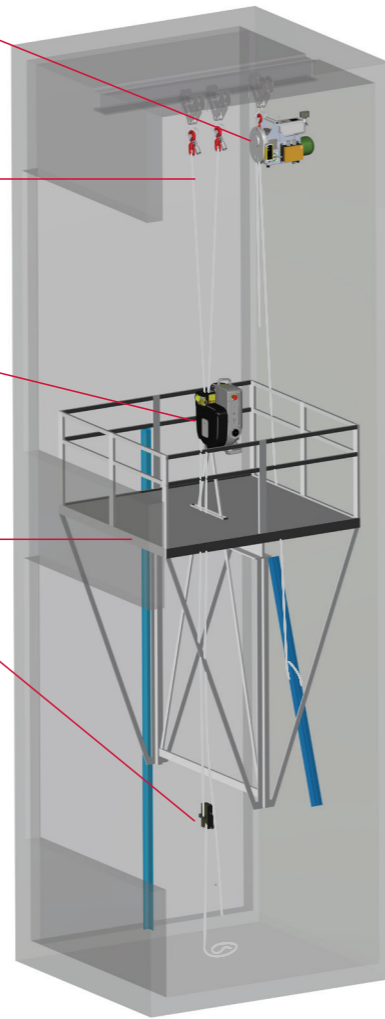

Application 1: False Car

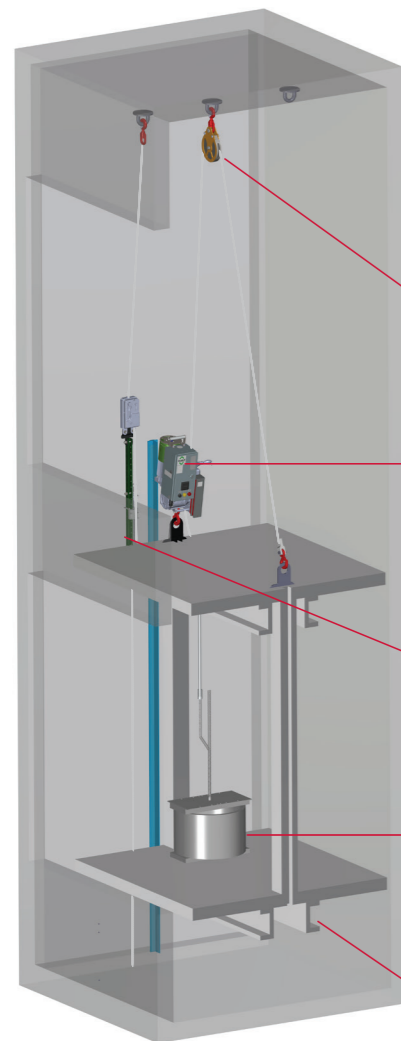

Application 2: Car Frame (2:1)

### Pulleys

- > Multiple options (see next page)

### Traction Hoist

- > Titan (500 kg, 650 kg)
- > UpPro 5S (500 kg)
- > UpPro 10 (1000 kg) (shown)
- > UpPro P2514 (2500 kg)

### Overspeed Safety Lock

- > 600/1000/2500 kg load capacities available
- > Hoist mounted OSL (1:1 applications)
- > Secondary OSL on extension bar (2:1 applications)

### Passive Wire Winder

- > Provides wire rope management
- > Reduces potential wire rope damage
- > No power required

### Elevator Car Frame (for reference only)

## Hoist Options

The broadest range of hoists available.

	Personnel Hoists			Material Hoist
	Titan	UpPro	UpPro P2514	UpLite Cargo
Working Load Limit	500/650 kg	500/1000 kg	2500 kg	100/300/500 kg
Speed	Single Speed 9 (m/min.)	Single Speed 9 or 18 (m/min.) Dual Speed 9/18 (m/min.) VFD Dual Speed 5/9 (m/min.) VFD Quad Speed 5/9/12/18 (m/min.)	VFD Quad Speed 5/9/12/18 (m/min.)	100 kg: 30 (m/min.) 300 kg: 15 (m/min.) 500 kg: 10 (m/min.)
Weight	30 kg	40/65 kg	155 kg	30 kg
Power Supply Options	230/400 V, 50/60 Hz, 1/3 Ph	230/400 V, 50/60 Hz, 1/3 Ph Contactor or VFD Technology	400 V, 50/60 Hz, 3 Ph VFD Technology	230V, 50/60 Hz, 1 Ph
Safety Options	Slack Rope Safety Overspeed Top Limit Switch	Upper limit switch Rope end switch Rail end switch (with rollers or magnetic)	Upper limit switch Rope end switch Rail end switch (with rollers or magnetic)	N/A
Dimensions (HxWxD)	610 x 356 x 305 mm	572 x 318 x 257 mm 640 x 261 x 407 mm	356 x 305 x 610 mm	356 x 305 x 610 mm

## Hoist Adapters

Adapters for UpPro hoists:



- > False car
- > Shackle
- > Eye-hook
- > Eye-hook & shock lanyard
- > Eye-hook, shock lanyard & deflection pulley

Note: Adapters for Titan hoists can be custom-made if required. Contact Power Climber for more information.

## Pulley Options

Multiple options available, including:



- > Load capacities ranging from 2 t to 5 t
- > One or two rollers
- > User protection casing
- > Swivel hook & optional rotation limiter system
- > Telescopic rod available
- > Compliant with EN 1808 standards

## UpPro Hoist Optional Accessories

- > Wire rope tension weight
- > Roller tension weight
- > Radio remote control
- > OSL adapter
- > Rope guide spring
- > H-Beam clamp
- > Emergency limit switch
- > Telescopic bar

## Variable Frequency Drive **Technology**

The **ONLY** VFD hoists specifically designed for the elevator industry.

With VFD, the motor speed varies based on input frequency and voltage.

- Perfect for poor quality power supply conditions. The system simply adjusts the speed to compensate for variations in voltage.
- Provides a soft start with no bounce, ideal for leveling and pull tests.
- Low starting voltage is a big advantage on sites with generator power.
- Works with both 50 Hz and 60 Hz power.
- Available with up to four speeds (5/9/12/18 m/min).



## Power Climber is there for **You.**

### Service

With facilities in North America, South America, Europe and Asia, as well as a global service network, Power Climber is positioned to support your business or project wherever it may be. Power Climber's reliable network of dealers and experienced factory-trained service professionals can troubleshoot any product-related issues, ensuring you receive timely and consistent service regardless of location.

### Training

Power Climber offers both **hands-on** and **remote** training classes for the maintenance and repair of our hoists.

In addition, Power Climber offers training for technicians to safely work with suspended access equipment. We have trained thousands of technicians all over the world. Our job is to help you do your job safely and efficiently.

#### Training benefits:

- Improves worker safety awareness
- Helps control accident-related costs
- Saves downtime due to operator errors
- Prevents damage to structures from equipment misuse
- Projects employee professionalism
- Shows commitment to employee safety



**Power Climber** has been a leader in the global suspended access industry since 1972, with facilities in the Americas, Europe, and Asia. We design, manufacture, and distribute hoists, platforms, rigging equipment, and accessories to rental companies and facility owners around the globe in applications ranging from commercial construction and renovation to industrial and infrastructure.

Visit  
Power  
Climber  
Online

